



Home Elevators



**Built for every day,
designed for any style.**





**Garaventa Lift has been moving people since 1928.
Our products have always stood the test of time.**

We began by building tramways in the Swiss Alps. Garaventa Lift has since become a global organization, representing reliability, safety, and innovation.

A Garaventa Home Elevator will quickly become part of everyday life. Choose from a variety of materials and finishes to fit any budget and style.

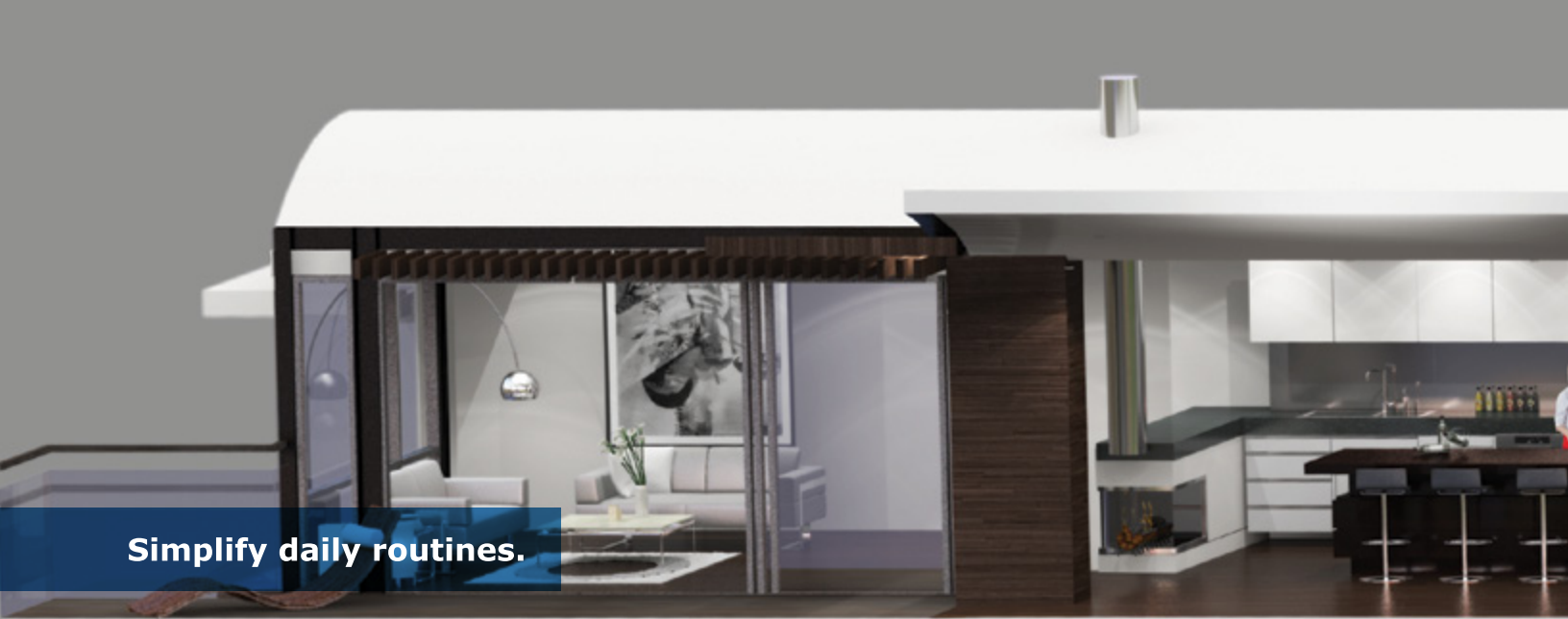

Simplify daily routines.

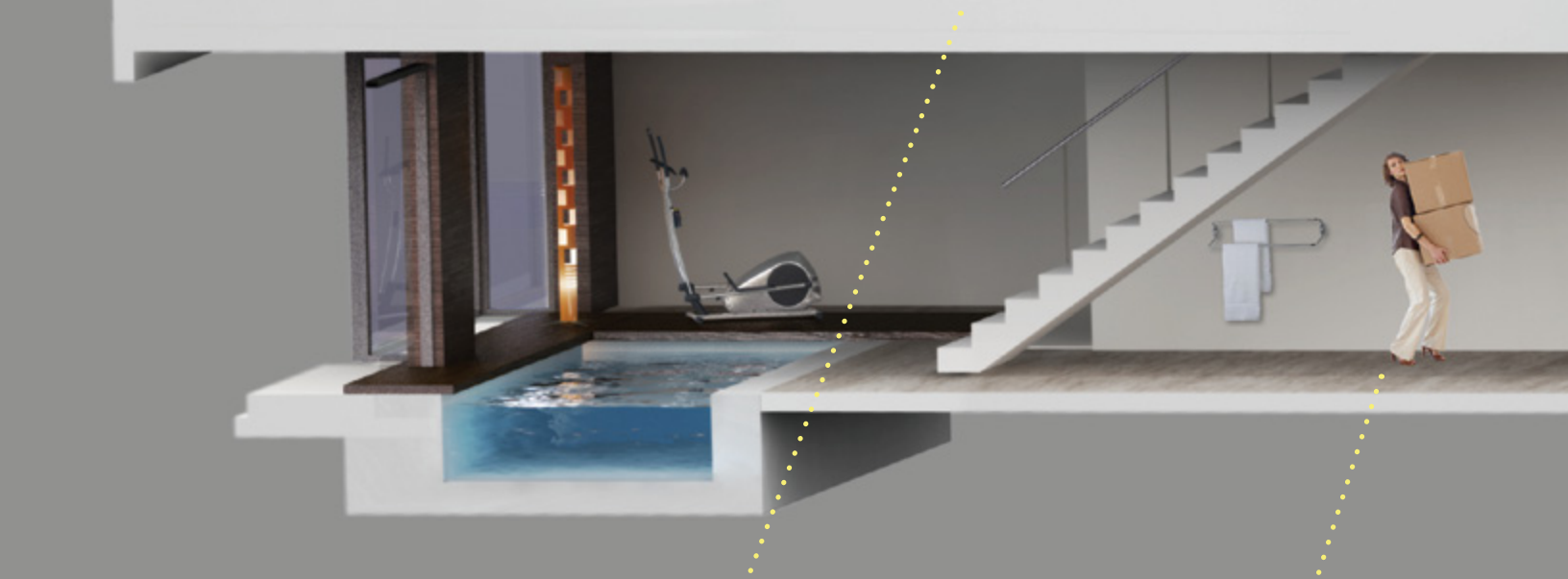
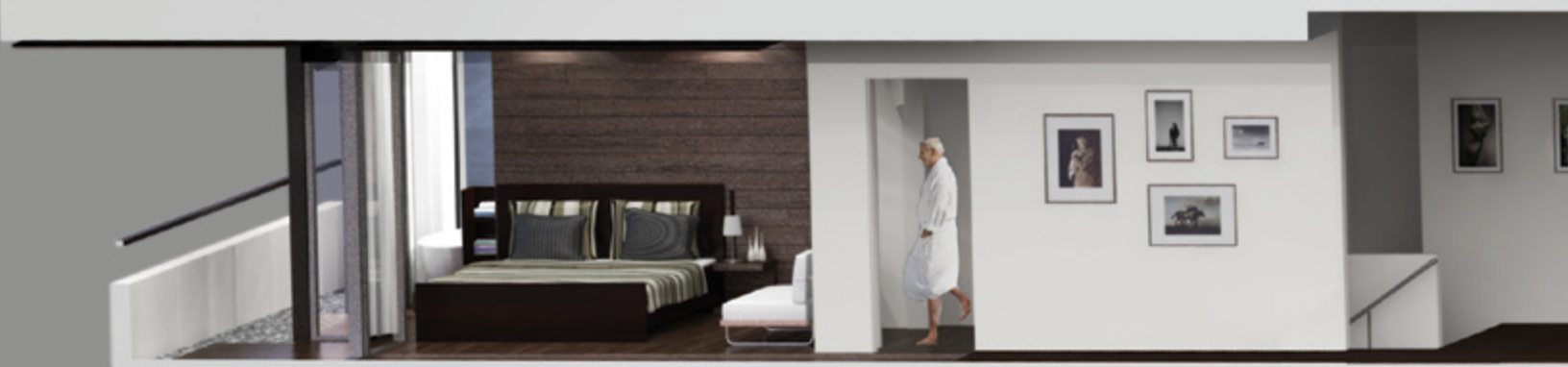

Daily routines made easier.

Reduce heavy lifting when transporting storage, laundry, or decorations.



Simplify multi-level entertaining.

Bring purchases home in one smooth trip.

Raised Panel

Raised panels in Oak, Maple, or Cherry give a traditional look to any application.

Available Finishes



Maple



Red Oak

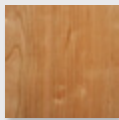

Cherry

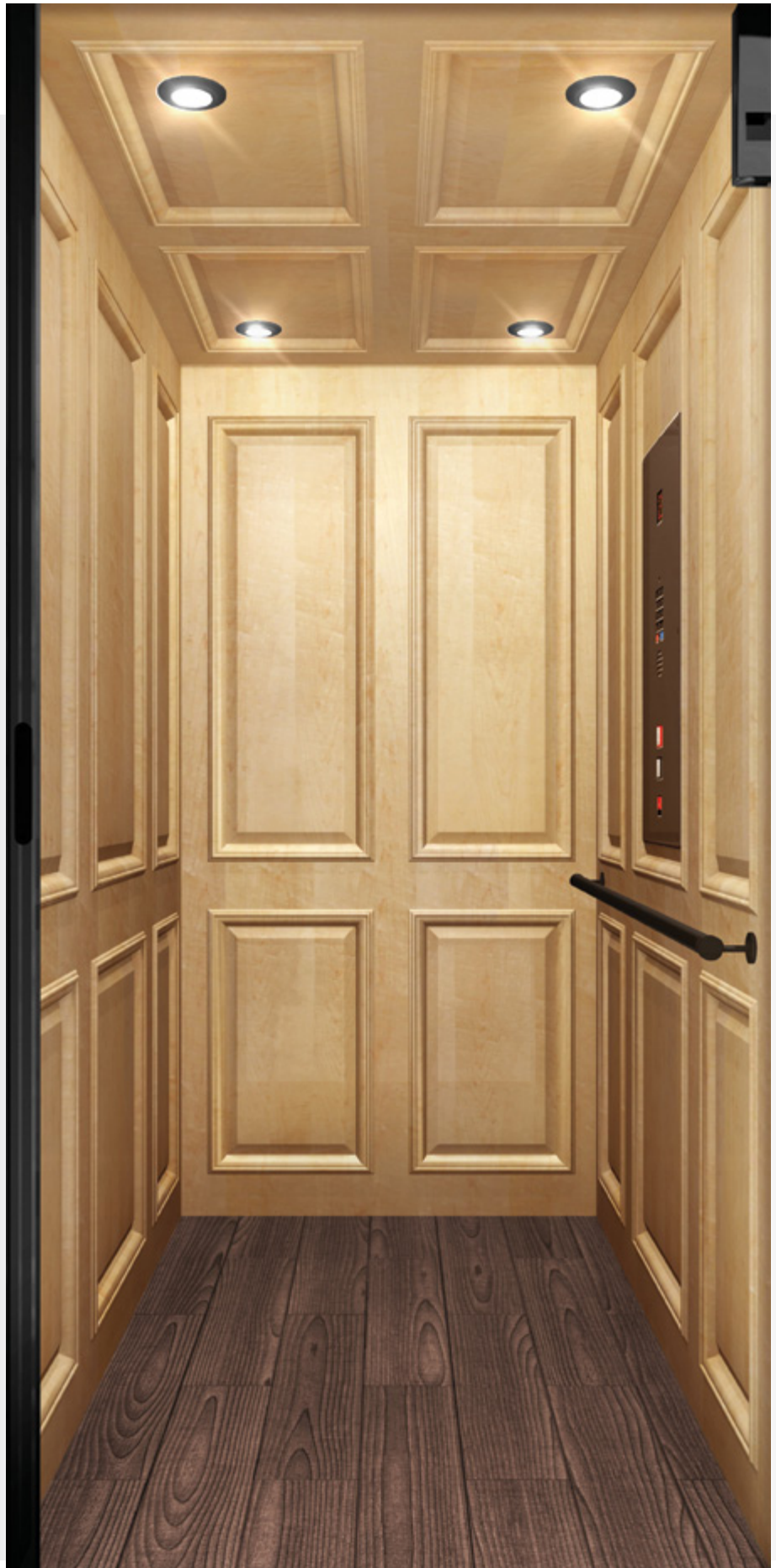



Recessed Panel

Recessed center panels give a modern take to a traditional look. Offered in Oak, Maple or Cherry.

Available Finishes

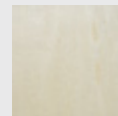

Maple

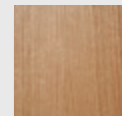

Red Oak

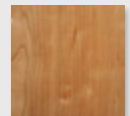

Cherry

Veneer Panel

Wood veneer offers a sleek wood option or a base for a cabinet finisher to add moldings to match any home decor.

Standard Veneers

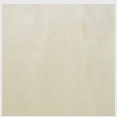

Maple

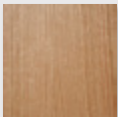

Red Oak

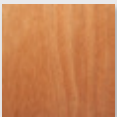

Mahogany

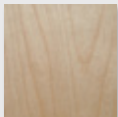

Birch

Optional Veneers

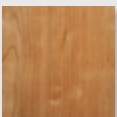

Cherry

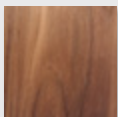

Walnut

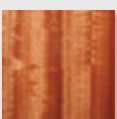

Makore

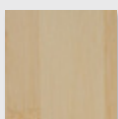

Bamboo

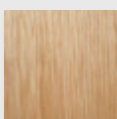

Hickory





Melamine Panel

Perfect for a durable, simple finish that is easy to maintain.

Available Finishes

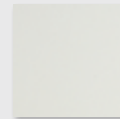

Super White



Antique White

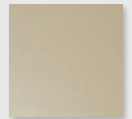

Sweet Beige

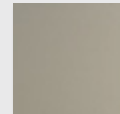

Willow Gray

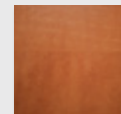

Sunrise Maple



Finnish Oak

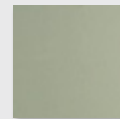

Calamare

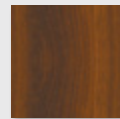

Authentic

Glass Panel

For a clean, modern, and open concept layout. Aluminum frames can be painted in white, black, or custom color.





Design It Yourself

Want an elevator, but undecided on the finishing? We provide the basics, and your builder finishes to your specifications.

Elevator Enclosure

Modular enclosures are available as an alternative to building an elevator hoistway.









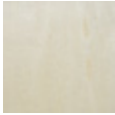
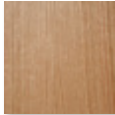

Glass Enclosure

Enjoy a panoramic view while traveling between floors. Enclosures are also available for assembly with glass panels.

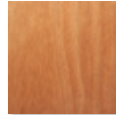
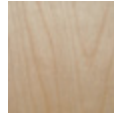
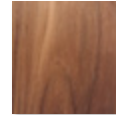
WALL FINISHES

Wood Veneers

									
	Maple	Red Oak	Cherry	Mahogany	Birch	Walnut	Hickory	Makore	Bamboo
Raised Panel	*	*	*						
Recessed Panel	*	*	*						
Standard Veneer	*	*		*	*				
Optional Veneer			*			*	*	*	*

Melamine

								
	Super White	Antique White	Sweet Beige	Willow Gray	Sunrise Maple	Finnish Oak	Calamare	Authentic
Melamine Cab	*	*	*	*	*	*	*	*

Further Options

Glass Cab	Aluminum frame painted in white / black / custom paint
Design It Yourself	Medium Density Fiberboard (MDF) cab walls

Hydraulic Drive

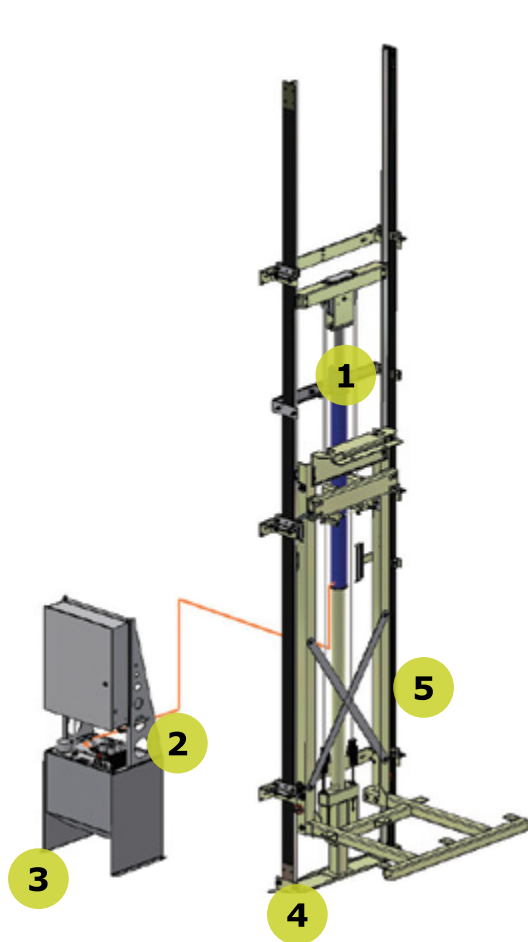

- 1** 1:2 Cable Hydraulic Drive
- 2** Two-speed hydraulic control valve provides smooth, comfortable starting and stopping.
- 3** Submersed hydraulic pump and motor ensures quiet operation.
- 4** Recommended pit depth: 8" (203 mm). Shallower depths may be feasible. Deeper pits may be required for larger cab sizes.
- 5** System utilizes a heavy duty car sling which provides uncompromised stability.

In-Line Drive



- 1** Controller box can be mounted above the rails* or in a remote location up to 50 ft. (15.2 m) away. **No machine room required!**
- 2** Direct drive electric motor located on top of the rail system
- 3** Counterweight frame
- 4** Recommended pit depth: 8" (203 mm). Shallower depths may be feasible.
- 5** Systems utilizes a heavy duty car sling which provides uncompromised stability.

* where permitted by code

Car Operating Panels

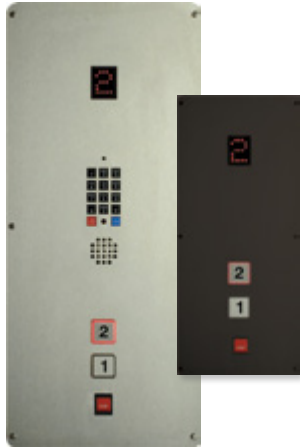

Includes a digital floor display, floor selection buttons and emergency stop/ alarm button. Floor selection buttons can be fitted with numbers or letters. Ensure passenger safety and security with an integral telephone. Available in brushed stainless steel or oil rubbed bronze finish. Custom finishes available on request.

Handrails



Brushed
Stainless Steel

Oil Rubbed
Bronze Finish

Available in two finishes, the handrail is located on the control wall. Custom finishes are available on request. Additional handrails can be mounted for extra passenger safety.

Hall Stations

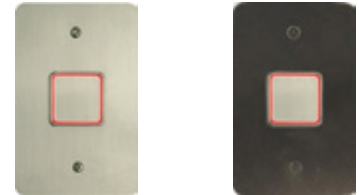

Brushed
Stainless Steel

Oil Rubbed
Bronze Finish

Hall station buttons illuminate when pushed. The push buttons are made of stainless steel for maximum durability. Wall plates are available in two standard finishes, brushed aluminum or oil-rubbed bronze finish. Custom finishes on wall plates are available on request.

Ceiling Lighting



Four recessed low-voltage light fixtures illuminate automatically when the car gate is opened. Available in white or black.

Flooring



The Garaventa Home Elevator is designed structurally to allow installation of 1/8" to 3/4" of flooring to match your home decor. Flooring will be supplied locally by others.

Keyed Hall Station



Brushed
Stainless Steel

Oil Rubbed
Bronze Finish

For increased safety and security, an optional key switch allows the entire elevator to be deactivated. Key switches can be custom designed to deactivate only certain hall stations or to control access to certain floors.

Doors



Residential swing doors are supplied by others. During the installation of your elevator, the doors are fitted with special interlocks. They will open only when the elevator car is at the same landing. Solid core or solid wood core doors are required. The doors can be equipped with an optional automatic door operator.

Sliding Doors

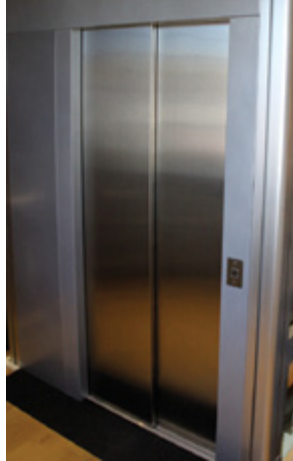

Garaventa Home Elevators are also available with two speed sliding doors (1400 lb. models only). These doors come standard as mild steel with a primer finish. Stainless steel doors with a brushed finish are available as an option.

Cab Gates

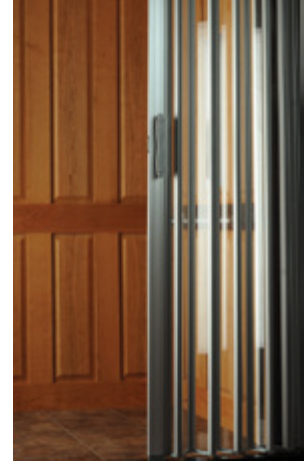

Standard



Optional



Design Assistance



www.garaventlift.com



Design Hotline: 1.800.663.6556 Toll Free North America

All cars are equipped with solid accordion gates. Standard manual operation or optional power gate operator available. Available in black, white, or Antique White with or without 3 clear vision panels. Optional: perforated aluminum, bronze acrylic, or clear acrylic panels. Custom finishes available.

SPECIFICATIONS

Overhead Clearance Required: (Measured from finished upper floor to ceiling above)

96" (2.4 m) Overhead required for in line drive with controller mounted remotely (84" (2.1 m) Cab height)

108" (2.7 m) Overhead required for in line drive with controller mounted above the rails (84" (2.1 m) Cab Height)

108" (2.7 m) Overhead required for in line drive with controller mounted remotely (96" (2.4 m) Cab height)

120" (3 m) Overhead required for in line drive with controller mounted above the rails (96" (2.4 m) Cab height)

96" (2.4 m) Overhead required for hydraulic drive (84" (2.1 m) Cab height)

108" (2.7 m) Overhead required for hydraulic drive (96" (2.4 m) Cab height)

Rated Load: Standard 750 lbs (340 kg) or 1,000 lbs (455 kg) | Optional 1,400 lbs (635 kg)

Speed: 40 ft/min (12.2 meters/min) nominal speed

Travel Range: Up to 50 feet (15.2 m) | 1400 lbs hydraulic model up to 36 feet (11 m)

Stops: Up to 6 stops

Controls: Fully automatic push button operation | Digital floor indicator in car | Automatic car lighting upon entry | Illuminated push buttons

Safety Features: Manual lowering capability | Safety brake system | Hall door interlocks, gate safety switch | Emergency stop and alarm | Solid accordion gate in car

Hydraulic Drive System: 1:2 cable hydraulic drive | Quiet submersed pump and motor | Two-speed valve for smooth start and stop

In-Line Drive System: Geared direct drive motor | Variable frequency drive for smooth start and stop

Power Requirements: 230 VAC single phase | Optional 208 VAC 3 phase (Hydraulic Drive only)

Popular Options: Keyed hall stations | Integral emergency telephone | Automatic car gate operator

Warranty: 2 year standard warranty | Optional additional 5 year extended warranty (7 years)

ENTRY & EXIT CONFIGURATIONS

The Garaventa Home Elevator system fits within a vertical elevator hoistway connecting the floors to be serviced. The elevator stops level with the bottom floor, thus a small pit is required. The recommended pit depth is 8" (203 mm) although shallower pit depths are feasible. Wider cabs require 12".

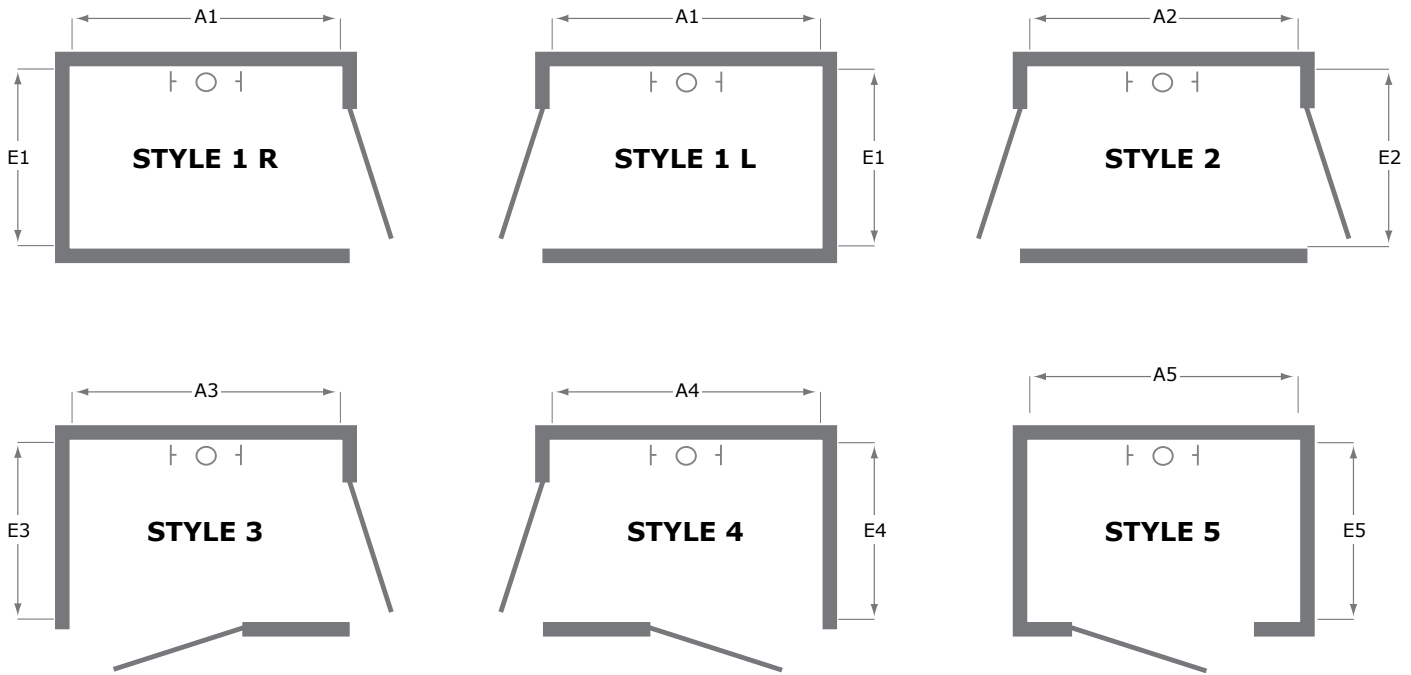

HOISTWAY DIMENSIONS

750 lbs (340 kg) or 1,000 lbs (455 kg) models only.

Car Size*	E1	A1	E2	A2	E3	A3	E4	A4	E5	A5
36" x 48" (914 x 1219)	50" (1270)	56 1/4" (1429)	50" (1270)	54 3/4" (1391)	53 7/8" (1368)	56 1/4" (1429)	53 7/8" (1368)	56 1/4" (1429)	53 7/8" (1368)	54 1/4" (1378)
36" x 54" (914 x 1372)	50" (1270)	62 1/4" (1581)	50" (1270)	60 3/4" (1543)	53 7/8" (1368)	62 1/4" (1581)	53 7/8" (1368)	62 1/4" (1581)	53 7/8" (1368)	60 1/4" (1530)
36" x 60" (914 x 1524)	50" (1270)	68 1/4" (1734)	50" (1270)	66 3/4" (1695)	53 7/8" (1368)	68 1/4" (1734)	53 7/8" (1368)	68 1/4" (1734)	53 7/8" (1368)	66 1/4" (1683)
40" x 54" (1016 x 1372)	54" (1372)	62 1/4" (1581)	54" (1372)	60 3/4" (1543)	57 7/8" (1470)	62 1/4" (1581)	57 7/8" (1470)	62 1/4" (1581)	57 7/8" (1470)	60 1/4" (1530)

* Custom sizes available

* 1400 lbs (635 kg) models are only available in larger sizes. Please contact Garaventa Lift for details.



Home Elevators

(800) 663-6556
www.garaventlift.com

© Garaventa Lift. As we are continuously improving our products, specifications outlined in this brochure are subject to change without notice. Due to the nature of the printing process, colors shown in the brochure may not be an accurate representation of the actual product.

37156-H-PB